

Fiji Accent Chair

Part # CH-FIJI XX+XX

20-0316

PARTS

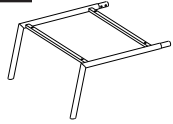

A

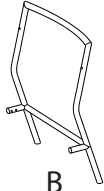

B



C

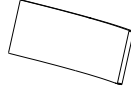

D



(M6x 38mm)
x2

E



F



G



(M6x 30mm)
x4

H



(M6x12mm)
x4

I

1

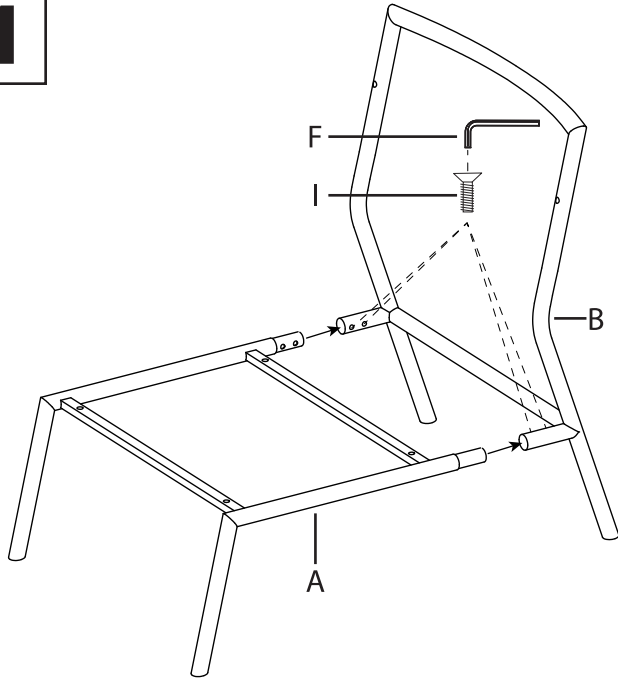

2

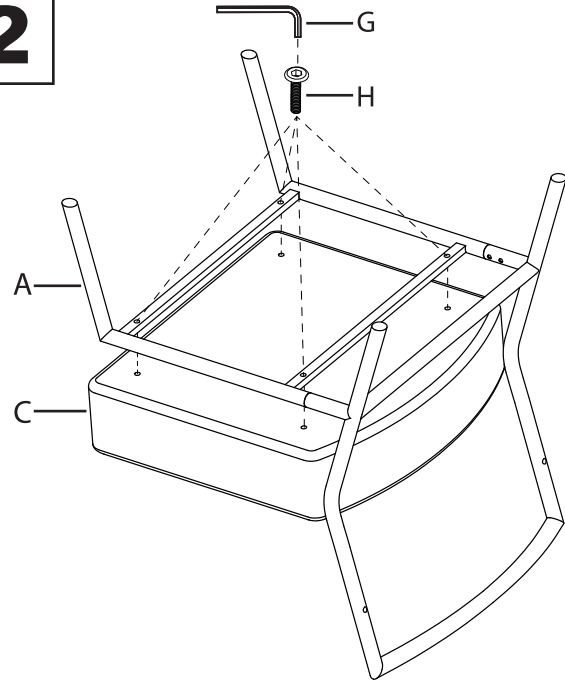

3

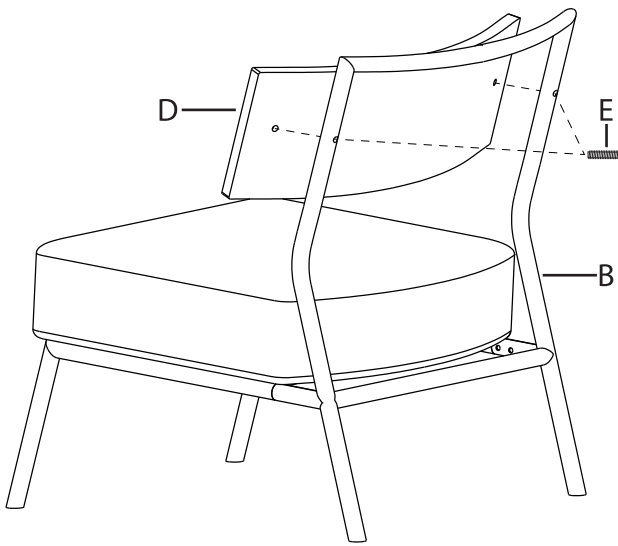

4

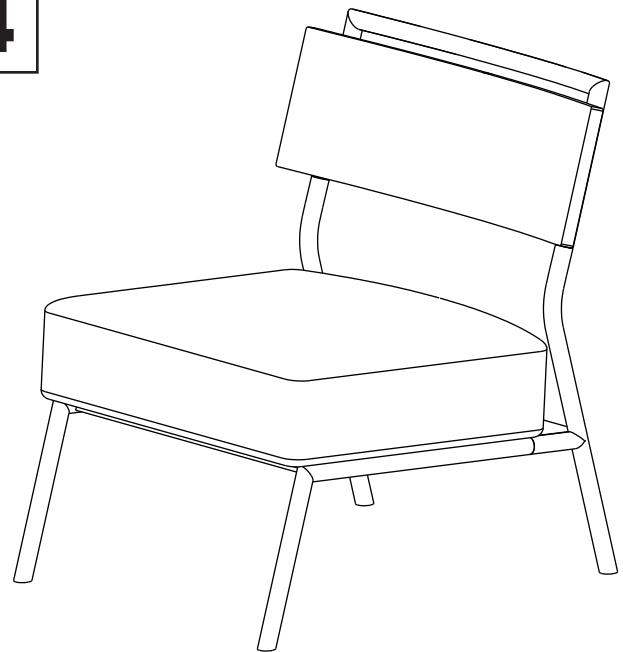

Do not over tighten.
Do not use power tools to assemble.